

# Y Series (16-26hp)

## R410A Heat Pump Outdoor Unit

### Improved for even higher efficiency

The City Multi Y series makes use of a two pipe refrigerant circuit throughout, with the choice of either Branch Pipe or Header Pipe feeds to indoor units, with manual changeover from cooling to heating to ensure that a constant indoor climate is maintained. Available in larger capacities for heating and cooling the system accommodates up to 32 indoor units for each outdoor unit.

- > Highest ever COP's / EER's due to new higher efficiency inverter technology
- > Energy-saving inverter driven outdoor compressor units with very low start currents
- > Choice of Branch Pipe or Header Pipe feeds to indoor units
- > No requirement for plant rooms or bulky service shafts
- > 3 capacities from 16hp to 26hp, 16hp using a single inverter compressor
- > Improved pipe run of 150m, with a total system pipe length of 300m
- > High Sensible Cooling Function - By raising the off coil temperature, a 10% increase in sensible cooling capacity over standard operation is achievable, the result being greater comfort for occupants



Technical Information >>

#### Y SERIES OUTDOOR UNIT-16-26hp

MODEL REFERENCE		PUHY-P400YGM-A	PUHY-P500YGM-A	PUHY-P650YGM-A
CAPACITY (kW)	Heating (nominal)	50.0	63.0	81.5
	Cooling (nominal)	45.0	56.0	73.0
	Heating (UK)	44.0	55.4	71.7
	Cooling (UK)	42.3	51.5	67.2
POWER INPUT (kW)	Heating (nominal)	12.43	15.89	19.82
	Cooling (nominal)	13.42	15.59	19.65
	Heating (UK)	12.06	14.62	18.23
	Cooling (UK)	9.80	10.91	13.76
MAX No. OF CONNECTABLE INDOOR UNITS		22	24	32
AIRFLOW (m3/min)	High	240	400	400
NOISE (dBA)		61	60	62
WEIGHT (kg)		275	455	455
DIMENSIONS (mm)	Width	1290	1990	1990
	Depth	840 (877)	840 (877)	840 (877)
	Height	1840	1840	1840
ELECTRICAL SUPPLY		380-415v, 50Hz	380-415v, 50Hz	380-415v, 50Hz
PHASE		3	3	3
STARTING CURRENT (A)	Inverter / DOL	8	8 / 92.5	8 / 92.5
RUNNING CURRENT (A)	Heating	19.2	24.5	30.6
	Cooling	20.7	24.0	30.3
FUSE RATING (BS88) – HRC (A)		40	50	63
MAINS CABLE No. Cores		4 + earth	4 + earth	4 + earth

PUHY-P400-650YGM-A Piping Restrictions	
TOTAL PIPING LENGTH	300m max
FURTHEST PIPING LENGTH	150m max
FURTHEST PIPING LENGTH AFTER 1st BRANCH	40m max
BETWEEN INDOOR AND OUTDOOR UNITS - HEIGHT	50m max (40m max if outdoor installed below)
BETWEEN INDOOR AND INDOOR UNITS - HEIGHT	15m max

### PUHY-P400YGM-A

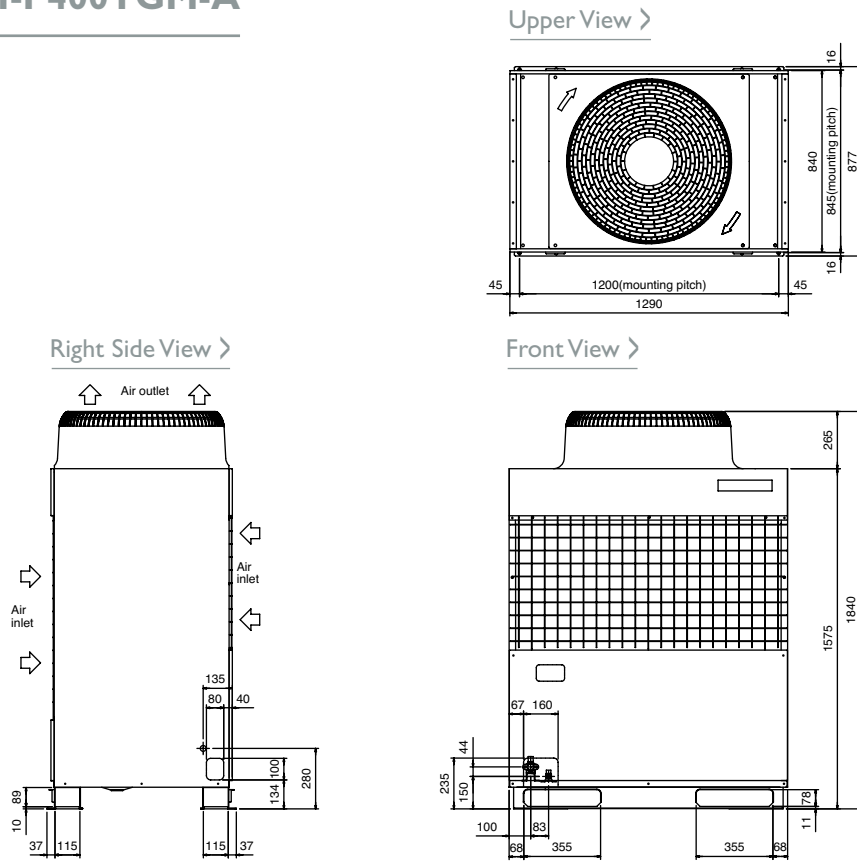

### PUHY-P500, 650YGM-A

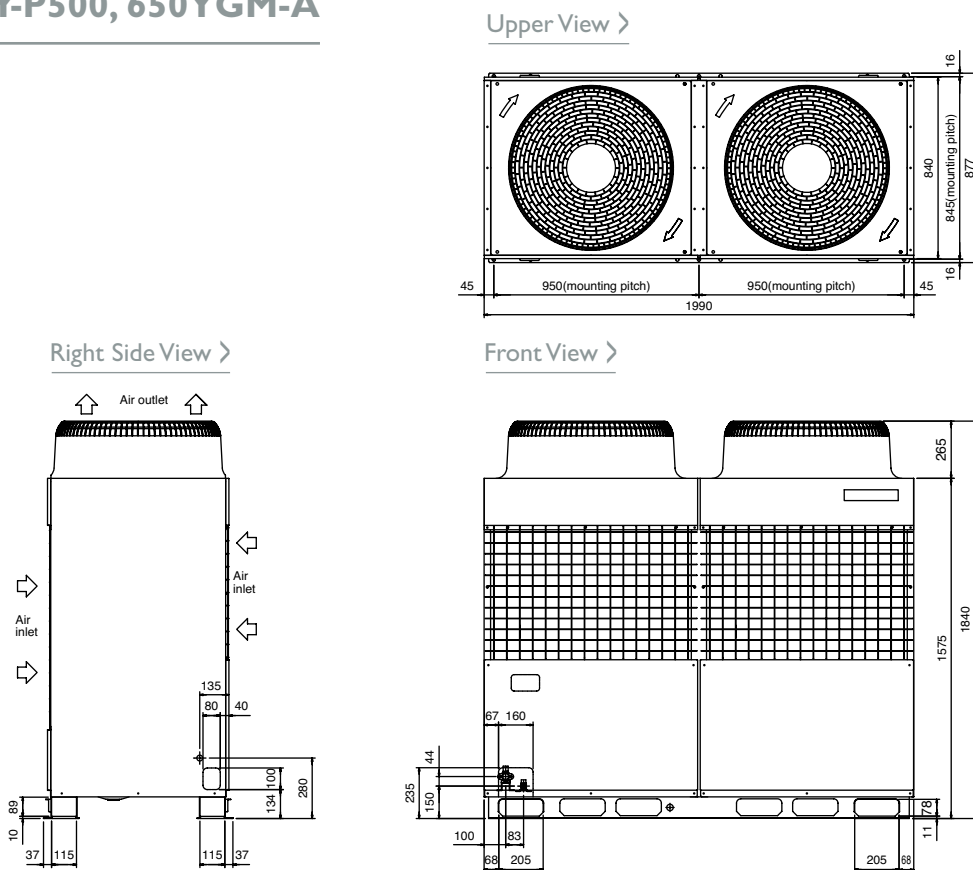

**This pdf has been downloaded from the website of :**

“Supplying and installing the latest in air conditioning technology”

**° Celsius**  
**air conditioning**

Celsius Air Conditioning Ltd, 1 Well Street, Heywood, Greater Manchester OL10 1NT

 01706 367 500  07000 CELSIUS  01706 367 355  sales@celsiusair.co.uk  www.celsiusair.co.uk

**www.celsiusair.co.uk**