

PRH-P-MYA Heat Pump

R407c Packaged Rooftop System

New Series

The rooftop cooling and heating system combines the economy and simplicity of split system technology with the flexibility of ducted air distribution. The compressor, evaporator and condenser units are combined into a fully integrated package which can supply efficient cooling or heating, all through conventional ducting and air grilles located throughout the building.

- > Supplied factory assembled, piped, internally wired and charged with refrigerant
- > High efficiency operation
- > Flexibility of supply air delivery



Technical Information >>

PRH-P-MYA - UNITS			
MODEL REFERENCE		PRH-P10MYA	PRH-P20MYA
CAPACITY (kW)	Heating (nominal)	30.5	61.0
	Cooling (nominal)	26.0	52.0
	Heating (UK)	25.95	51.85
	Cooling (UK)	24.2	48.4
SHF (nominal)		0.81	0.81
AIRFLOW (m ³ /min)	Indoor Side	90	180
	Outdoor Side	185	185 x 2
EXTERNAL STATIC PRESSURE (Pa)	Lo-Hi	100	200
NOISE (dBA)		60	63
DIMENSIONS (mm)	Width	2000	2000
	Depth	926	2130
	Height	1715	1735
WEIGHT (kg)		412	872
ELECTRICAL SUPPLY		380-415v, 50Hz	380-415v, 50Hz
PHASE		3	3
POWER INPUT (kW)	Heating/Cooling (nominal)	9.82 / 10.22	19.24 / 21.44
	Heating/Cooling (UK)	8.74 / 8.69	17.12 / 18.22
STARTING CURRENT (A)		134	155
RUNNING CURRENT (A)	Heating/Cooling	18.2 / 18.8	35.4 / 36.6
FUSE RATING (BS88) – HRC (A)		40	63
MAINS CABLE No. Cores		5	5
Charge R407c (kg)		8.2	8.2 x 2

UNIT PRH-PI0MYA

Upper View >

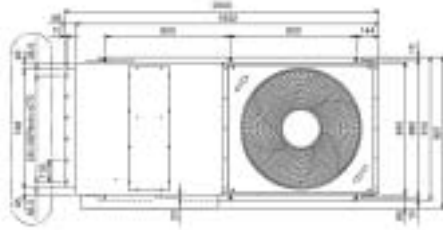

Side View >

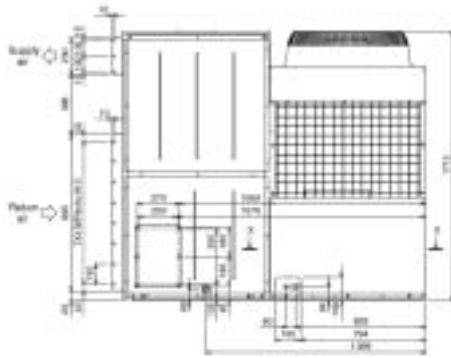

Rear View >

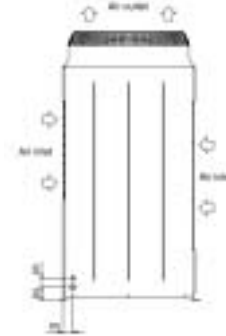

UNIT PRH-P20MYA

Upper View >

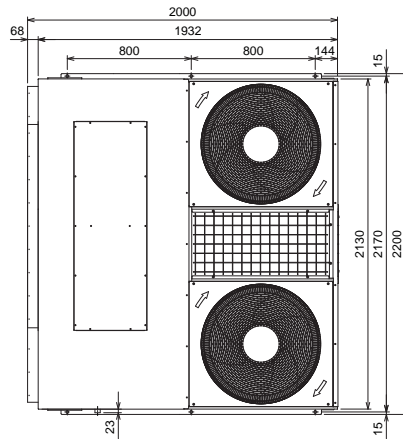

Side View >

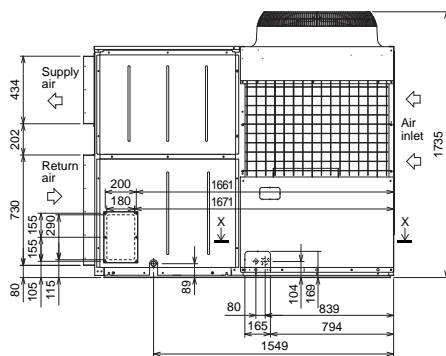

Rear View >

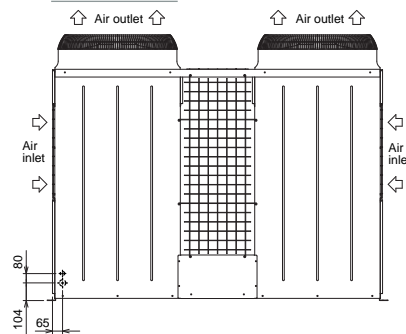

This pdf has been downloaded from the website of :

“Supplying and installing the latest in air conditioning technology”

° Celsius
air conditioning

Celsius Air Conditioning Ltd, 1 Well Street, Heywood, Greater Manchester OL10 1NT

 01706 367 500  07000 CELSIUS  01706 367 355  sales@celsiusair.co.uk  www.celsiusair.co.uk

www.celsiusair.co.uk